

High Production Icers

Belshaw's HI-series Donut Icers provide fast, uniform icing of cake and yeast-raised donuts, without the need for hands directly touching the product or icing.

- Full screens (or baking pans) can be easily iced in one minute or less with consistent, uniform coverage. Easy changeover to different flavors is accomplished by using extra Icing Pans.
- HI18F ices 24 donuts at a time, on 17" x 25" glazing screens or 18" x 26" baking pans. The capacity of the HI18F is approximately 120 dozen donuts per hour.
- HI24F ices up to 36 donuts at a time, on 24" x 24" glazing screens. The capacity of the HI24F is approximately 180 dozen donuts per hour.
- The HI18 and HI24's donut handling system submerges one side of the donuts into warm icing, held in a large capacity Icing Pan and warmed from below by a uniform radiant Heating Panel.
- For high capacity production, several icers may be used simultaneously. The large, easy to use submerging handle can be placed on either side, enabling one person to conveniently operate two icers at a time. An extra lift handle is optional to enable operation from both sides as needed.

ELECTRONIC TEMPERATURE CONTROLLER

- HI18F and HI24F feature an electronic temperature controller to manage icing temperature. The controller allows the operator to set and monitor temperature on an LCD display.



Electronic Temperature Controller

ACCESSORIES

- Catch Pan. When the icer is in use, the optional Catch Pan is swung into position so it is under the donuts just after they are coated with icing.
- Extra Icing Pans. The Icing Pan holds the icing in the icer. One Icing Pan is supplied with every Icer. Extra Icing Pans may be ordered and the pans can be quickly inserted whenever needed. Extra pans can be stored on the shelves beneath icer.
- Extra Heating Panels. Used to warm an Icing Pan containing donut icing. Extra Heating Panels can be used to warm other icing flavors. Extra heating panels can be stored on shelves beneath icer.
- Screens for holding donuts
 - Part # SL200-0004. 17" x 25" screen, holds 24 standard donuts.
 - Part # HG24-0001. 24" x 24" screen, holds 36 standard donuts.
 - 18" x 26" baking pans may be used instead of screens. A simple adapter is supplied for changeover.
- Extra Lift Handle. Enables operation from both sides as needed.
- Height Adjustment Kit. Allows for tray adjustment to ice products with heights 3/8 inch to 3 1/2 inch (10 mm to 90 mm).
- Belshaw CP-1/CP-2 Proofing Cabinet. Can be used to warm icing buckets ready for use.



HI18F (With Donut Tray Closed)



HI24F (With Donut Tray Open)



HI18F With Donut Tray Open



Catch Pan Option



Height Adjuster Option



Option For Warming Icing: CP1 Cabinet Proofer

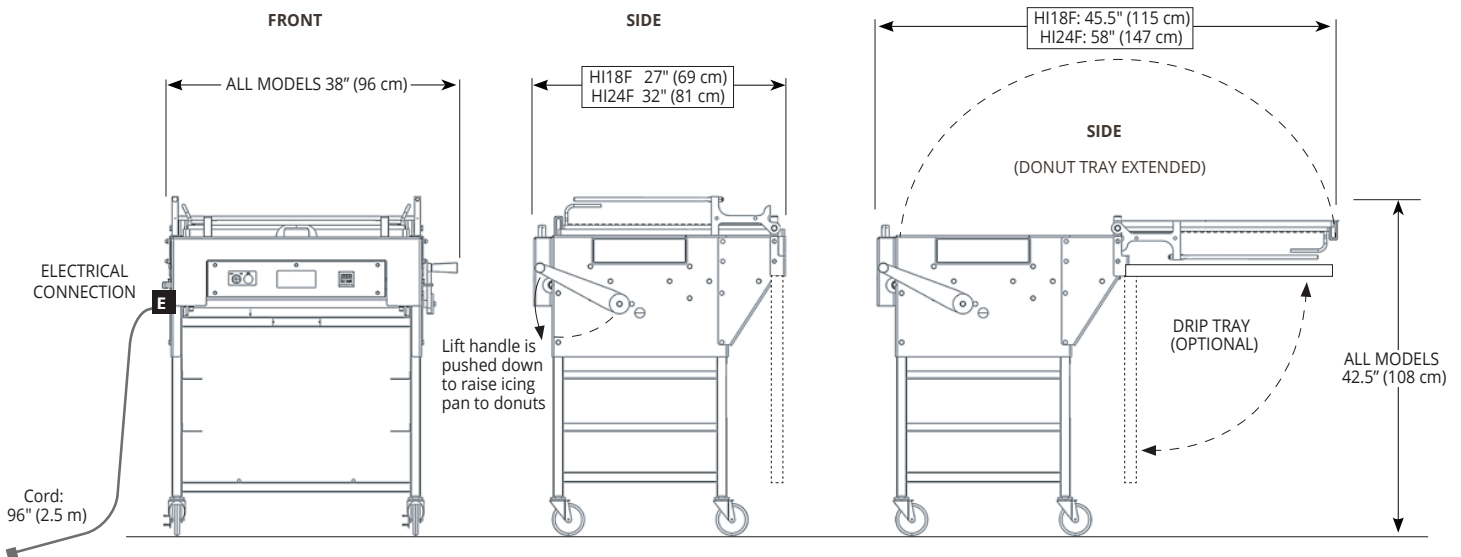

STANDARD FEATURES

- Electronic heat controller, maximum temperature 130° F (54.5° C).
- High temperature limit switch.
- Sturdy front cover to prevent damage to controls.
- Large, easy to use operating handle for submerging donuts.
- Supplied on right side of icer, field reversible to left side.
- Stainless steel cover for Icing Pan.
- 3 storage shelves for additional Icing Pans, Heating Panels, Screens or sheet pans.
- 4 casters, 2 lockable.
- 120V or 208-240V models available.

CERTIFICATIONS

- Certified to UL-197, CSA 22.2, and NSF-4.
- CE models available.

ACCESSORIES	HI18F	HI24F
Glazing Screens	SL200-0004	HG24-0001
Icing Pans	HI18-0001	HI24-0006
Heating Panel (120V)	HI18-1300	HI24-1300
Heating Panel (240V)	HI18-1300-240	HI24-1300-240
Heating Panel (240V) CE/European Union models	HI18-1300-240CE	HI24-1300-240CE
Drip Tray	HI18-1510	HI24-1510
Extra Lift Handle Kit	HI18-1507	
Height Adjustment Kit	HI18-1005	

SPECIFICATIONS

	HI18F	HI24F
COMPATIBLE GLAZING SCREENS	17" x 25"	24" x 24"
	part number	
	SL200-0004	HG24-0001
BAKING PAN SIZE	18" x 26"	24" x 24"
ICING PAN CAPACITY (Approximate)	50 lbs	60 lbs
	22.7 kg	27.3 kg
	7 gal	8.3 gal
	26 liters	31.3 liters
ELECTRICAL DATA		
120V, 60hz, 1ph	7.5 Amps	10 Amps
	0.9 KW	1.2 KW
208-240V, 50/60hz, 1ph	2.5 - 3.1 Amps	4.3 - 5 Amps
	0.5 - 0.7 KW	0.9 - 1.2 KW
Extra heating panels require their own connection.		
PLUG	NEMA 5-15P	120V
	NEMA 6-15P	240V N.America
	CEE 7/7	240V International
CORD length	96 inches (2.5 m)	
SHIPPING DIMENSIONS (Approximate, shipped in carton on pallet or crate)	48" x 42" x 54"	48" x 42" x 54"
	122x107x137 cm	122x107x137 cm
	250 lbs	300 lbs
	114 kg	136 kg